

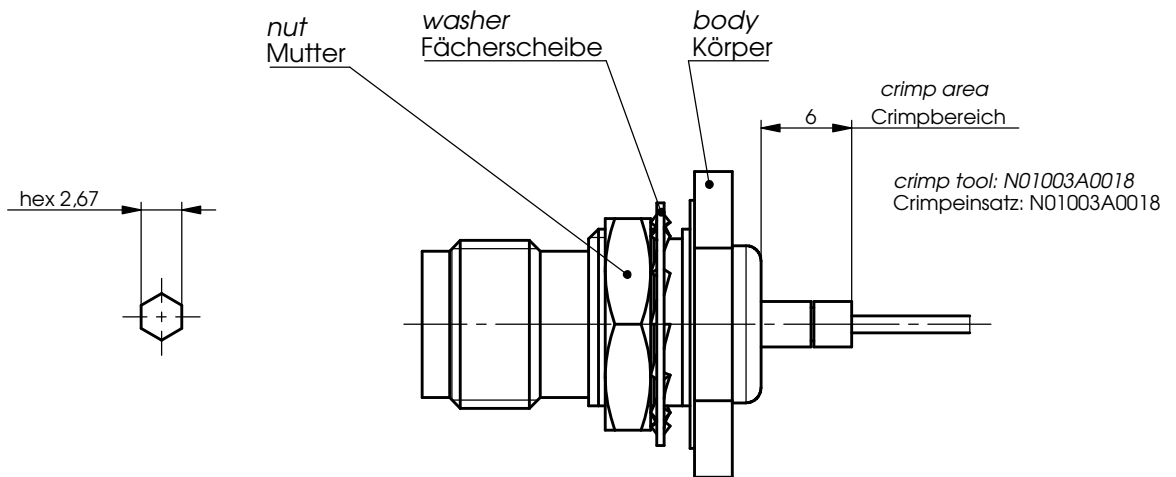

stripping instruction / Abisoliermaße

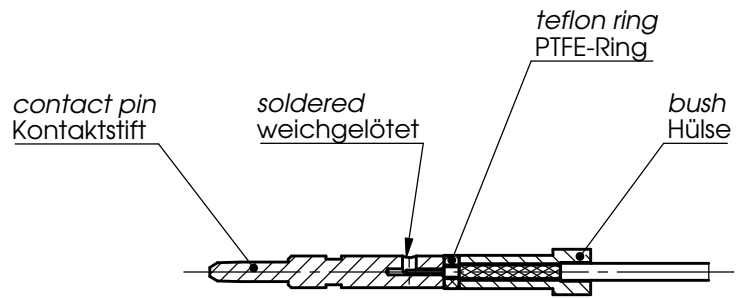
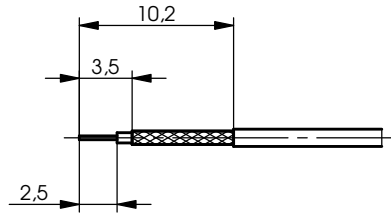
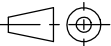

Alle Rechte vorbehalten / all rights reserved © Telegärtner K.Gärtner GmbH D-71144 Steinbronn Lerchenstrasse 35 Germany Phone: +49 7157/125-0 Fax: +49 7157/125-120 www.telegartner.com

Änd./ rev. index	Änderungs-Nr. / revision code	Datum/ date	Name/ name	Datum/ date	Name/ name	
				gez./ drawn	16.09.2014	KL
				gepr./ appr.	16.09.2014	BJ
Maßstab/ scale		Benennung/ title				
2:1		<b>Assembly Instruction</b> <b>Montageanweisung</b>				
Untert./ doc. type		Zeichnungsnr./ drawing no.		 Maße/ dimensions: mm Original : DIN A4 Blatt/ sheet 1 von/ of 1		
M		J01011R0010				
Ersatz für/ replaces		J01011R0065				