

insert prepared cable into the connector until stop  
vorbereitetes Kabel bis zum Anschlag in Steckverbinder schieben

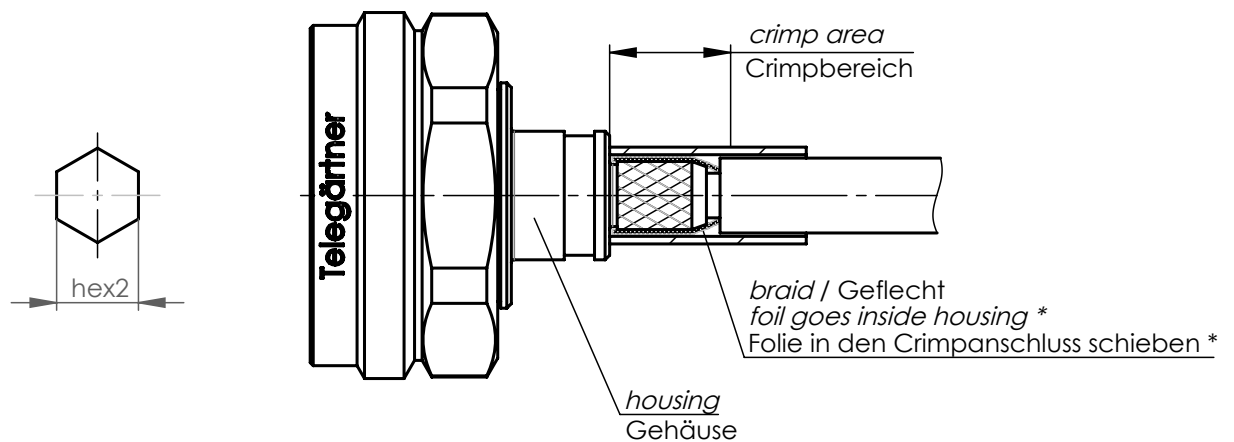

\* only for cables with foil / nur für Kabel mit Folie

xx	crimp insert Crimpeinsatz	hex1 x length 6kt1 x Länge	hex2 x length 6kt2 x Länge	stripping instruction Abisoliermaße
05	N01003A0005	1,69x2,5	5,41x8	

Änd./ rev. Index	Änderungs-Nr. / revision code	Datum/ date	Name/ name
Original	A4	Blatt/ sheet 1 von/ of 1	

	Datum/ date	Name/ name
gez./ drawn	05.07.2017	HR
gepr./ appr.	05.07.2017	KL
Maßstab/ scale	2:1	

Benennung/ title <b>Series 4.3-10 crimp / crimp Serie 4.3-10 crimp / crimp</b>	
Untert./ doc. type	Zeichnungsnr./ drawing no. <b>R T00100B4200</b>
Ersatz für / replaces	

